

MATRIX

VERSA SERIES

VS-S331





ENG	To download the latest owner's manual, in the language of your choice, visit the website above. For further assistance, Matrix contact information is on the next page.
GER	Das neueste Benutzerhandbuch in der Sprache Ihrer Wahl können Sie auf der zuvor genannten Website herunterladen. Falls Sie weitere Hilfe benötigen, finden Sie die Matrix-Kontaktinformationen auf der nächsten Seite.
FRE	Pour télécharger la version la plus récente du guide d'utilisation dans la langue de votre choix, visitez le site ci-dessus. Si vous avez besoin d'aide, rendez-vous sur la page suivante pour obtenir les coordonnées de Matrix.
SPE	Para descargar el último manual de usuario en el idioma que prefiera, visite el sitio web anterior. Si necesita más ayuda, la información de contacto de Matrix se encuentra en la página siguiente.
DUT	Ga naar de bovenstaande website om de laatste gebruikershandleiding te downloaden in de taal van uw keuze. Voor extra hulp vindt u de Matrix-contactgegevens op de volgende pagina.
DAN	Du kan downloade den seneste brugsvejledning på dit foretrukne sprog fra webstedet ovenfor. Hvis du har brug for yderligere hjælp, henvises du til Matrix' kontaktoplysninger på næste side.
ITA	Per scaricare il più recente manuale del proprietario, nella lingua che preferisci, visita il sito Web indicato in precedenza. Per ulteriore assistenza, le informazioni di contatto per Matrix si trovano alla pagina successiva.
GRK	Για λήψη του πιο πρόσφατου εγχειριδίου χρήστη, στη γλώσσα της επιλογής σας, επισκεφθείτε την παραπάνω ιστοσελίδα. Για περαιτέρω βοήθεια, πληροφορίες επικοινωνίας με την Matrix παρέχονται στην επόμενη σελίδα.
POL	Aby pobrać najaktualniejszą wersję instrukcji obsługi w wybranym języku, należy odwiedzić powyższą stronę internetową. Jeśli potrzebna jest dalsza pomoc, można skorzystać z informacji kontaktowych Matrix podanych na kolejnej stronie.
PRB	Para baixar a versão mais recente do nosso manual em seu idioma, acesse o site acima. Para obter mais assistência, as informações de contato da Matrix estão na próxima página.
CHT	若要下載您所選語言版本的最新使用手冊，請造訪上述網站。 如需其他協助，請參閱下一頁的 Matrix 聯絡資訊。
JPN	ご希望の言語版の最新オーナーズマニュアルは、上記ウェブサイトからダウンロードしてください。 さらにサポートが必要な場合は、次ページに記載されているMatrixお問い合わせ窓口までご連絡ください。
KOR	선택한 언어로 최신 사용설명서를 다운로드하려면 위의 웹 사이트를 참조하십시오. 추가 지원이 필요한 경우 다음 페이지에 있는 Matrix 연락처 정보로 요청하십시오.
VTM	Để tải về sách hướng dẫn sử dụng mới nhất, bằng ngôn ngữ của bạn, hãy truy cập trang web bên trên. Để được trợ giúp thêm, thông tin liên lạc của Matrix có ở trang kế tiếp.
THI	ท่านสามารถดาวน์โหลดคู่มือผู้ใช้ล่าสุดในภาษาที่ต้องการได้จากเว็บไซต์ข้างต้น หากท่านต้องการความช่วยเหลืออื่นๆ โปรดติดต่อไปยังข้อมูลติดต่อ Matrix ที่ให้ไว้ในหน้าถัดไป
ARB	هالعلاب بوللا عقوم ةدرابزب لصفف ،اهاراتخف ففلالاب ،كلاللل لفلد ثدأ لفلزنفل ةفلالل ةحفصلل فف Matrix ةكرفشب ةصلال لاصفال تامولعم دجوت ،ةدعاسمل نم دفرمف



MATRIX

AUSTRALIA

Johnson Health Tech Australia
6B Hazelwood Drive
Morwell
VIC 3840 AUSTRALIA
Tel: +61 1300 760 601
au.matrixfitness.com

BRAZIL

Johnson Health Tech Brasil
Estrada Municipal, 200 – mód 14 e 15 – gleba 3
Chácara Alvorada
Indaiatuba, SP
CEP 13337-200 BRASIL
Tel: +55-19-2107-5300
br.matrixfitness.com

CANADA

Johnson Health Tech Canada
10401, Ray-Lawson Blvd.
Montreal, Quebec H1J 1M3
CANADA
Tel: 514-336-0006
www.matrixfitness.com

CHINA

Johnson Health Tech (Shanghai) Co., Ltd.
Rm 508-512
HuaWen Plaza 999 Zhongshan
(West) Road
Changning District
Shanghai, 200050 CHINA
Tel: +86-021-32503800
www.johnsonfitness.com.cn

FRANCE

Johnson Health Tech France
45, avenue Georges Politzer
Trappes
78190 FRANCE
Tel: +33 01 30 68 62 80
www.matrixfitness.fr

GERMANY / AUSTRIA

Johnson Health Tech. GmbH
Nikolaus-Otto-Str. 1
D-22946 Trittau GERMANY
Tel. +49 (0)4154-7952-0
www.matrixfitness.eu

GREECE

Johnson Health Tech Hellas SA
12 Vas. Konstantinou Avenue
116 35 Athens GREECE
Tel: +20 211 4112797
www.Johnson Health Tech.gr

HONG KONG

Johnson Health Tech (HK) Limited
Room 1501-1502, Aitken Vanson Centre,
61 Hoi Yuen Road, Kwun Tong
Kowloon
HONG KONG
Tel: +852-2302 0596
hk.matrixfitness.com

IBERIAN PENINSULA (SPAIN, PORTUGAL)

Johnson Health Tech Ibérica
Avenida de la Astronomía, 4 nave 9.2
San Fernando de Henares
28830 Madrid - ESPAÑA
Tel: +34-91 6293 688
www.matrixfitness.es

ITALY

Johnson Health Tech Italia Spa
Zona Ind.le Campolungo 11
63100 Ascoli Piceno (AP)
ITALY
Tel: +39 0736 22699
www.matrixfitness.it

JAPAN

Johnson Health Tech Japan
Yasuda Bldg. 2F,
3-3-8 Kaigan,
Minato-ku Tokyo 108-8435
JAPAN
Tel: +81-3-5419-3560
www.matrixfitness.jp

KOREA

Johnson Health Tech Co., Ltd. Korea Branch
203 ho, A-Block Richensia Young
San133-3 Wonhyoro 1-ga, Young San
Gu, 140-111 Seoul
SOUTH KOREA
Tel: +82-2-6731-0175
kr.matrixfitness.com

MALAYSIA

Johnson Fitness (Malaysia) Sdn. Bhd.
Lot 557D, Jalan Subang 3
Subang Jaya Industrial Estate
47610 Subang Jaya
Selangor MALAYSIA
Tel: +60-603-5632 8273
my.matrixfitness.com

NETHERLANDS (BELGIUM, DENMARK, LUXEMBOURG)

Matrix Fitness / Johnson Health Tech. Netherlands
Vleugelboot 14
3991 CL Houten
NETHERLANDS
Tel: +31 30 24 45 435
www.matrixfitness.nl

PHILIPPINES

Johnson Health Tech. Commercial Philippines Inc.
15th Floor, Citibank Center, 8741 Paseo de Roxas,
Makati City, Metro Manila, 1226 PHILIPPINES
Tel: +63-2-558-6590
world.matrixfitness.com

POLAND

Johnson Health Tech Poland
ul. Działkowa 62
02-234 Warszawa POLAND
Tel: +49 2234 9997-100
pl.matrixfitness.com

SWITZERLAND

Johnson Health Tech. (Schweiz) GmbH
Althardstrasse 185
CH-8105 Regensdorf SWITZERLAND
Tel. +41 (0)44-843 30 30
www.matrixfitness.ch

TAIWAN

Johnson Health Tech Taiwan
999, Sec 2, Dongda Rd., Daya Dist.,
Taichung City 428
TAIWAN (R.O.C)
Tel: +886-4-25667100
world.matrixfitness.com/zh

THAILAND

Johnson Health Tech Thailand
9th Floor, Unit 9B, Bangna Towers,
Tower A 2/3
Moo 14, Bangna-Trad Rd.
K.M. 6.5 Bangkaew, Pangplee
Samutprakan, 10540 THAILAND
Tel: +66-2751-9360
th.matrixfitness.com

UNITED ARAB EMIRATES

Johnson Health Tech. UAE
ICON Tower, Office #602
TECOM, Al Barsha
Dubai, United Arab Emirates
Tel: +971 4 4567939
world.matrixfitness.com/

UNITED KINGDOM

(ENGLAND, SCOTLAND, N. IRELAND, WALES)
Johnson Health Tech UK
Riverside park
Campbell Road
Stoke on Trent
ST4 4EY ENGLAND
Tel: +44-1782644900
www.matrixfitness.co.uk

UNITED STATES

Matrix Fitness / Johnson Health Tech NA
1600 Landmark Drive
Cottage Grove, WI 53527 USA
Toll Free: +1-866-693-4863
www.matrixfitness.com

VIETNAM

Johnson Health Tech (Vietnam) Co. Ltd.
Unit 2302, Lim Tower
9-11 Ton Duc Thang Street
Ben Nghe Ward, District 1
Ho Chi Minh City
VIETNAM
Tel: +84 909 977957
vn.matrixfitness.com

INTERNATIONAL (OTHER COUNTRIES)

Matrix Fitness International
999, Sec 2, Dongda Rd., Daya Dist.,
Taichung City 428
TAIWAN (R.O.C)
Tel: +886-4-25667100
world.matrixfitness.com



Lat Pulldown

Place thigh pad on top of legs

Stretch

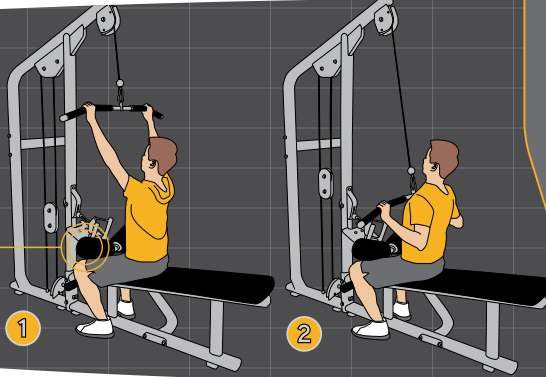

Seated Row

Raise thigh pad

Stretch

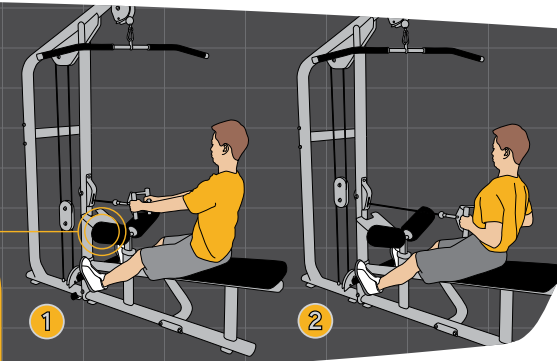

Lat Pulldown

MATRIX

Seated Row





IMPORTANT SAFETY INFORMATION

It is the sole responsibility of the purchaser of MATRIX products to instruct all individuals, whether they are the end user or supervising personnel on proper usage of the equipment.

It is recommended that all users of MATRIX exercise equipment be informed of the following information prior to its use.

Do not use any equipment in any way other than designed or intended by the manufacturer.

It is imperative that MATRIX equipment be used properly to avoid injury.

INSTALLATION

1. **STABLE AND LEVEL SURFACE:** MATRIX exercise equipment must be installed on a stable base and properly leveled.
2. **SECURING EQUIPMENT:** Manufacturer recommends that all stationary MATRIX strength equipment be secured to the floor to stabilize equipment and eliminate rocking or tipping over. This must be performed by a licensed contractor.

All anchor points must be able to withstand 750 lbs. (3.3 kN) pull-out force.

MAINTENANCE

1. **DO NOT** use any equipment that is damaged and or has worn or broken parts. Use only replacement parts supplied by your country's local MATRIX dealer.
2. **MAINTAIN LABELS AND NAMEPLATES:** Do not remove labels for any reason. They contain important information. If unreadable or missing, contact your MATRIX dealer for a replacement.
3. **MAINTAIN ALL EQUIPMENT:** Preventative maintenance is the key to smooth operating equipment as well as keeping your liability to a minimum. Equipment needs to be inspected at regular intervals.
4. Ensure that any person(s) making adjustments or performing maintenance or repair of any kind is qualified to do so. MATRIX dealers will provide service and maintenance training at our corporate facility upon request.

ADDITIONAL NOTES

This equipment should only be used in supervised areas where access and control is specifically regulated by the owner. It is up to the owner to determine who is allowed access to this training equipment. The owner should consider a user's: degree of reliability, age, experience, etc.

This training equipment meets industry standards for stability when used for its intended purpose in accordance with the instructions provided by the manufacturer.

This equipment is for indoor use only. This training equipment is a Class S product (designed for use in a commercial environment such as a fitness facility). This training equipment is in compliance with EN ISO 20957-1 and EN 957-2.

WARNING

DEATH OR SERIOUS INJURY CAN OCCUR ON THIS EQUIPMENT. FOLLOW THESE PRECAUTIONS TO AVOID INJURY!

1. Keep children under the age of 14 away from this strength training equipment. Teenagers must be supervised at all times while using this equipment.
2. This equipment is not intended for use by persons with reduced physical, sensory or mental capabilities, or lack of experience and knowledge, unless they have been given supervision or instruction concerning use of the equipment by a person responsible for their safety.
3. All warnings and instructions should be read and proper instruction obtained prior to use. Use this equipment for its intended purpose ONLY.
4. Inspect the machine before use. **DO NOT** use machine if it appears damaged or inoperable.
5. Do not exceed weight capacity of this equipment.
6. Check to see that the selector pin is completely inserted into the weight stack.
7. **NEVER** use the machine with the weight stack pinned in an elevated position.
8. **NEVER** use dumbbells or other means to incrementally increase the weight resistance. Only use the means provided directly from the manufacturer.
9. Injuries to health may result from incorrect or excessive training. Cease exercise if you feel faint or dizzy. Obtain a medical exam before beginning an exercise program.
10. Keep body, clothing, hair, and fitness accessories free and clear of all moving parts.
11. Adjustable stops, where provided, must be used at all times.
12. When adjusting any adjustable mechanism (stop position, seat position, pad location, range of motion limiter, pulley carriage, or any other type), make certain that the adjustable mechanism is fully engaged prior to use to prevent unintended motion.
13. Manufacturer recommends that this equipment be secured to the floor to stabilize and eliminate rocking or tipping over. Use a licensed contractor.
14. If equipment is **NOT** secured to floor: **NEVER** allow resistance straps, ropes or other means to be attached to this equipment, as this may result in serious injury. **NEVER** use this equipment for support during stretching, as this may result in serious injury.
15. **DO NOT REMOVE THIS LABEL. REPLACE IF DAMAGED OR ILLEGIBLE.**



PROPER USAGE

1. Do not exceed weight limits of the exercise device.
2. If applicable, set safety stops to appropriate height.
3. If applicable, adjust seat pads, leg pads, foot pads, range of motion adjustment, or any other type of adjustment mechanisms to a comfortable start position. Make certain that the adjusting mechanism is fully engaged to prevent unintentional movement and to avoid injury.
4. Sit on bench (if applicable) and get into appropriate position for exercise.
5. Exercise using no more weight than you can safely lift and control.
6. In a controlled manner, perform exercise.
7. Return weight to its fully-supported start position.

WARRANTY

For North America, please visit www.matrixfitness.com for warranty information along with warranty exclusions and limitations.

MAINTENANCE CHECKLIST

ACTION	FREQUENCY
Clean Upholstery ¹	Daily
Inspect Cables ²	Daily
Clean Guide Rods	Monthly
Inspect Hardware	Monthly
Inspect Frame	Bi-Annually
Clean Machine	As Needed
Clean Grips ¹	As Needed
Lubricate Guide Rods ³	As Needed

¹ Upholstery & Grips should be cleaned with a mild soap and water or a non-ammonia based cleaner.

² Cables should be inspected for cracks or frays and immediately replaced if present. If excessive slack exists cable should be tightened without lifting the head plate.

³ Guide rods should be lubricated with Teflon based lubricant. Apply the lubricant to a cotton cloth and then apply up and down the guide rods.

PRODUCT SPECIFICATIONS

Max User Weight	136 kg / 300 lbs.
Max Training Weight	107 kg / 235 lbs.
Product Weight, Heavy Stack	278 kg / 613 lbs.
Heavy Weight Stack	104 kg / 230 lbs.
Light Weight Stack	73 kg / 160 lbs.
Add-On-Weight	2.3 kg / 5 lbs. effective resistance
Overall Dimensions (L x W x H)*	210 x 158 x 227 cm / 82.5 x 62.2 x 89.1"

* Ensure a minimum clearance width of 0.6 meters (24") for access to and passage around MATRIX strength equipment. Please note, 0.91 meters (36") is the ADA recommended clearance width for individuals in wheelchairs.



UNPACKING

Thank you for purchasing a MATRIX Fitness product. It is inspected before it is packaged. It is shipped in multiple pieces to facilitate the compact packaging of the machine. Prior to assembly, confirm all the components by matching them with the exploded diagrams. Carefully unpack the unit from this box and dispose of the packing materials in accordance with your local laws.

CAUTION

To avoid injury to yourself and prevent damage to the frame components, be sure to have proper assistance removing the frame pieces from this box. Please be sure to install the equipment on a stable base, and properly level the machine. Ensure a minimum clearance width of 0.6 meters (24") for access to and passage around MATRIX strength equipment. Please note, 0.91 meters (36") is the ADA recommended clearance width for individuals in wheelchairs.

TOOLS REQUIRED FOR ASSEMBLY (not included)

3MM L-Shaped Allen Wrench

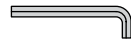

4MM L-Shaped Allen Wrench



5MM L-Shaped Allen Wrench



6MM L-Shaped Allen Wrench



8MM L-Shaped Allen Wrench



10MM L-Shaped Allen Wrench



Phillips Screwdriver



8MM Open-End Wrench



17MM Open-End Wrench



Guide Rod Lubrication



VS-S331 TRAINING AREA

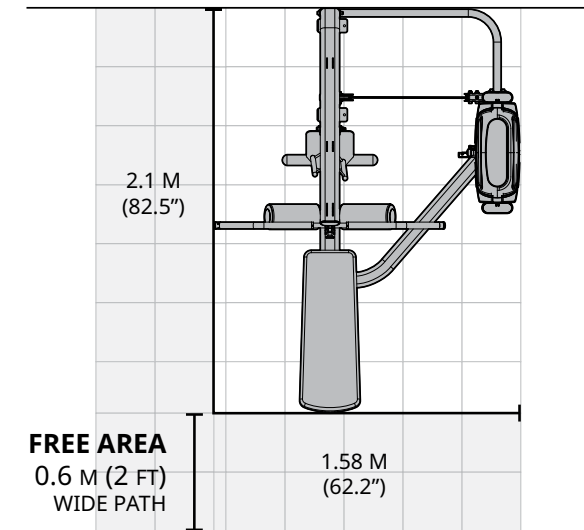

If any items are missing please contact your country's local MATRIX dealer for assistance.

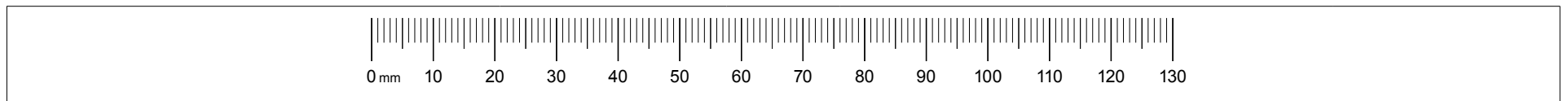

1

Do not fully tighten frame connectors until assembly is complete. Vibra-Tite 135 Red Gel or equivalent must be used on all fasteners that are not assembled with Nylock Nuts.

Step 1 Hardware

Description	Qty
A Bolt (M10x125L)	4
B Arc Washer (Φ10.2)	8
C Nut (M10)	10
D Screw (M10x20L)	4
E Bolt (M10x20L)	2
F Bolt (M10x80L)	4
G Bolt (M10x135L)	2
H Spring Washer (M10)	4
I Flat Washer (M10)	18

Torque Value

77 Nm / 57 ft-lb

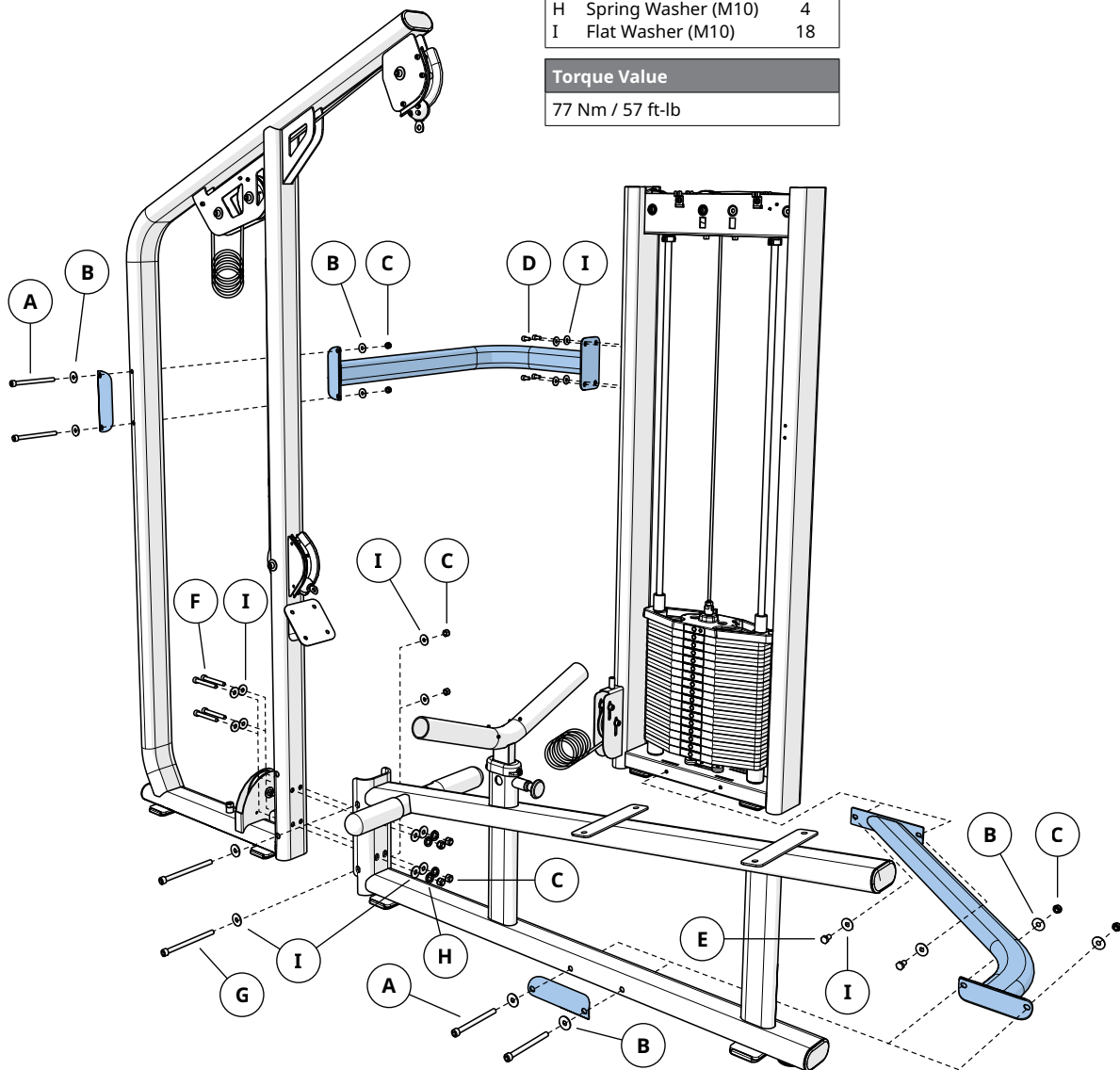

2

Step 2 Hardware

Description	Qty
J Nut (M8)	4

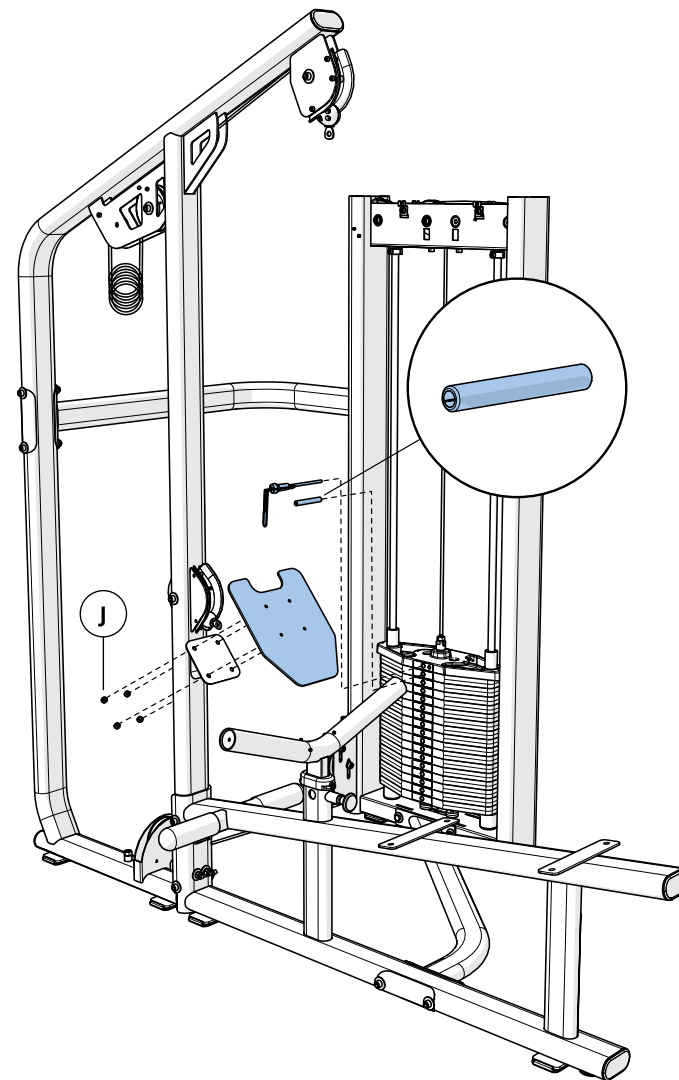



3

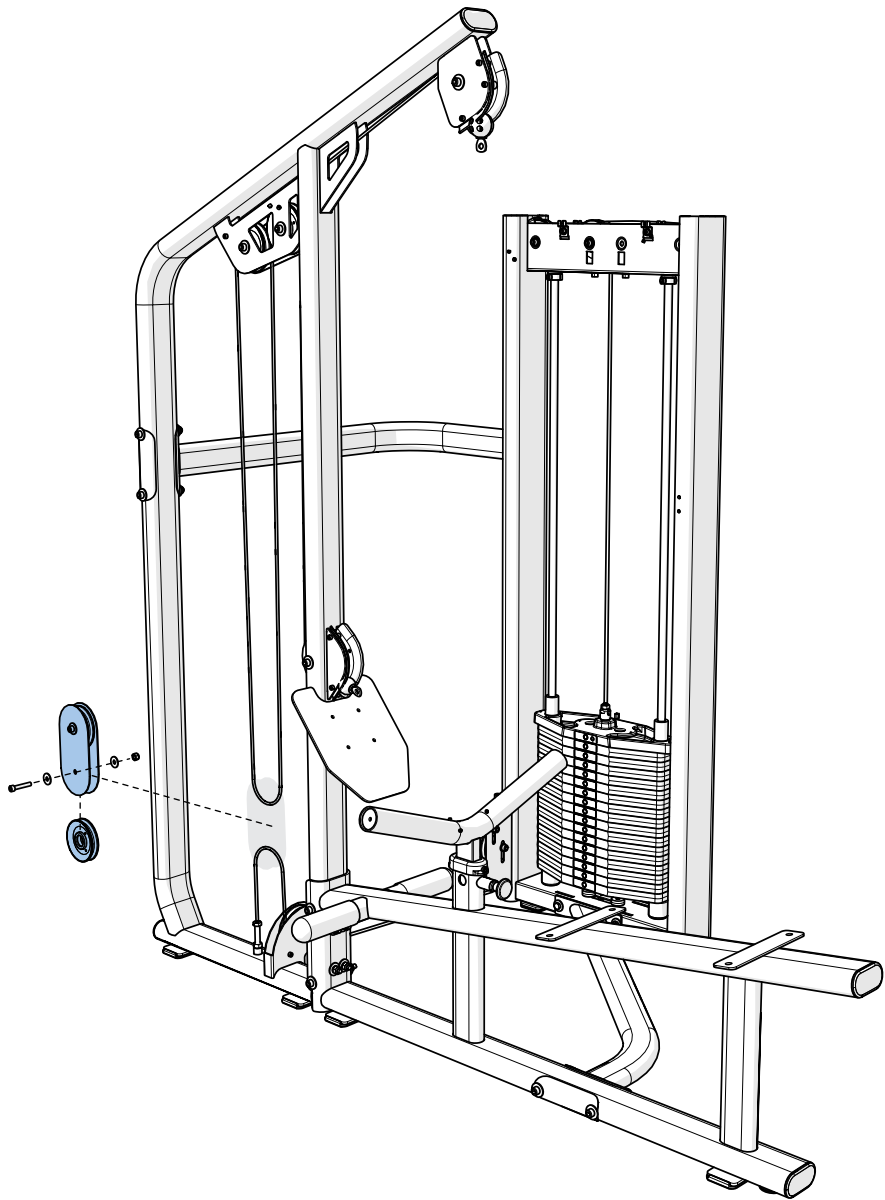

4

Use shims if base is not level.

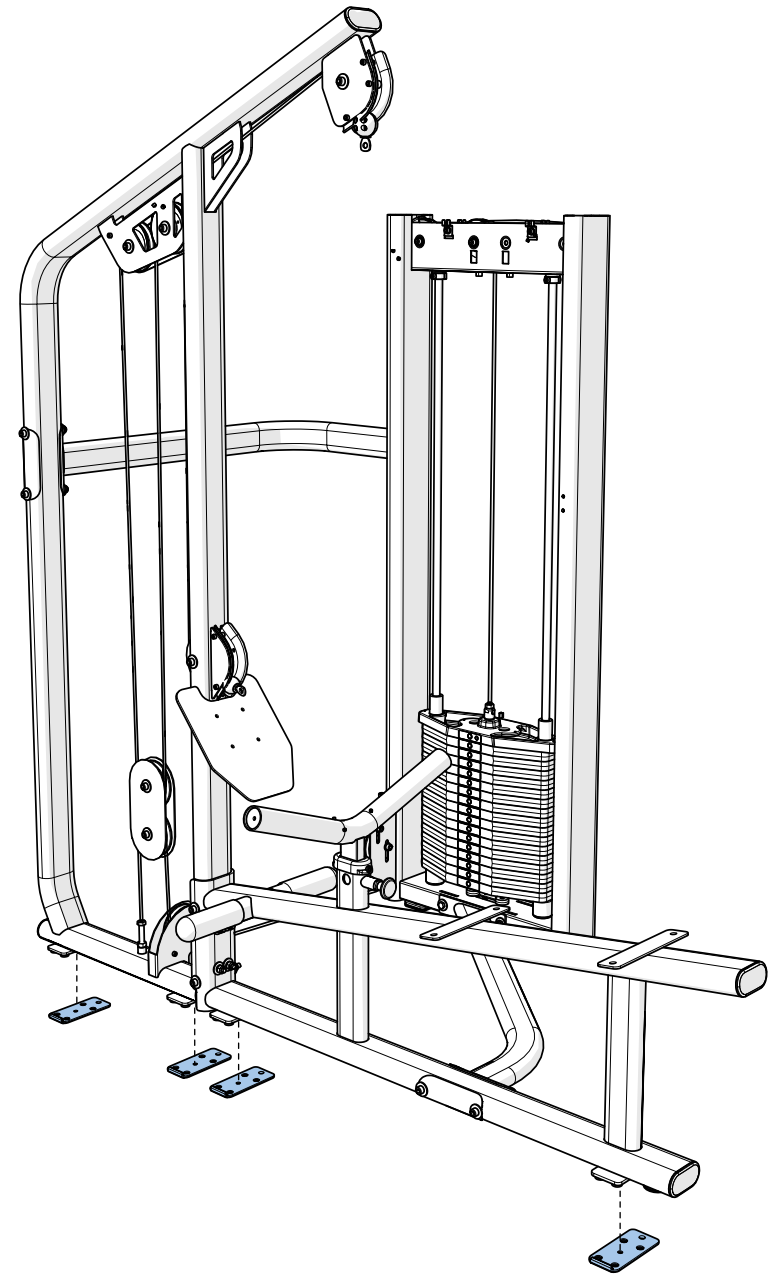

5

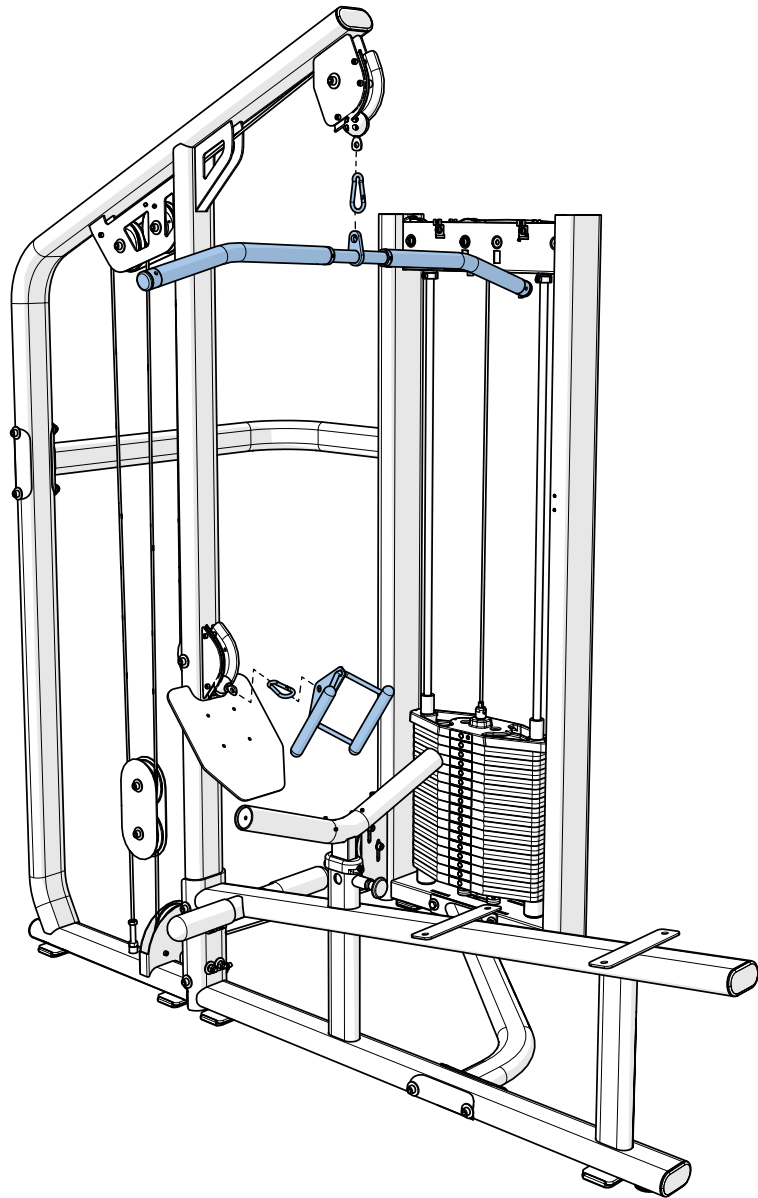

6

Step 6 Hardware

Description	Qty
K Bolt (M10x30L)	4
I Flat Washer (Φ10.2)	4
L Bolt (M8x25L)	2
M Bracket	2
N Sleeve	2

Torque Values

K	10 Nm / 7 ft-lb
L	25 Nm / 18 ft-lb

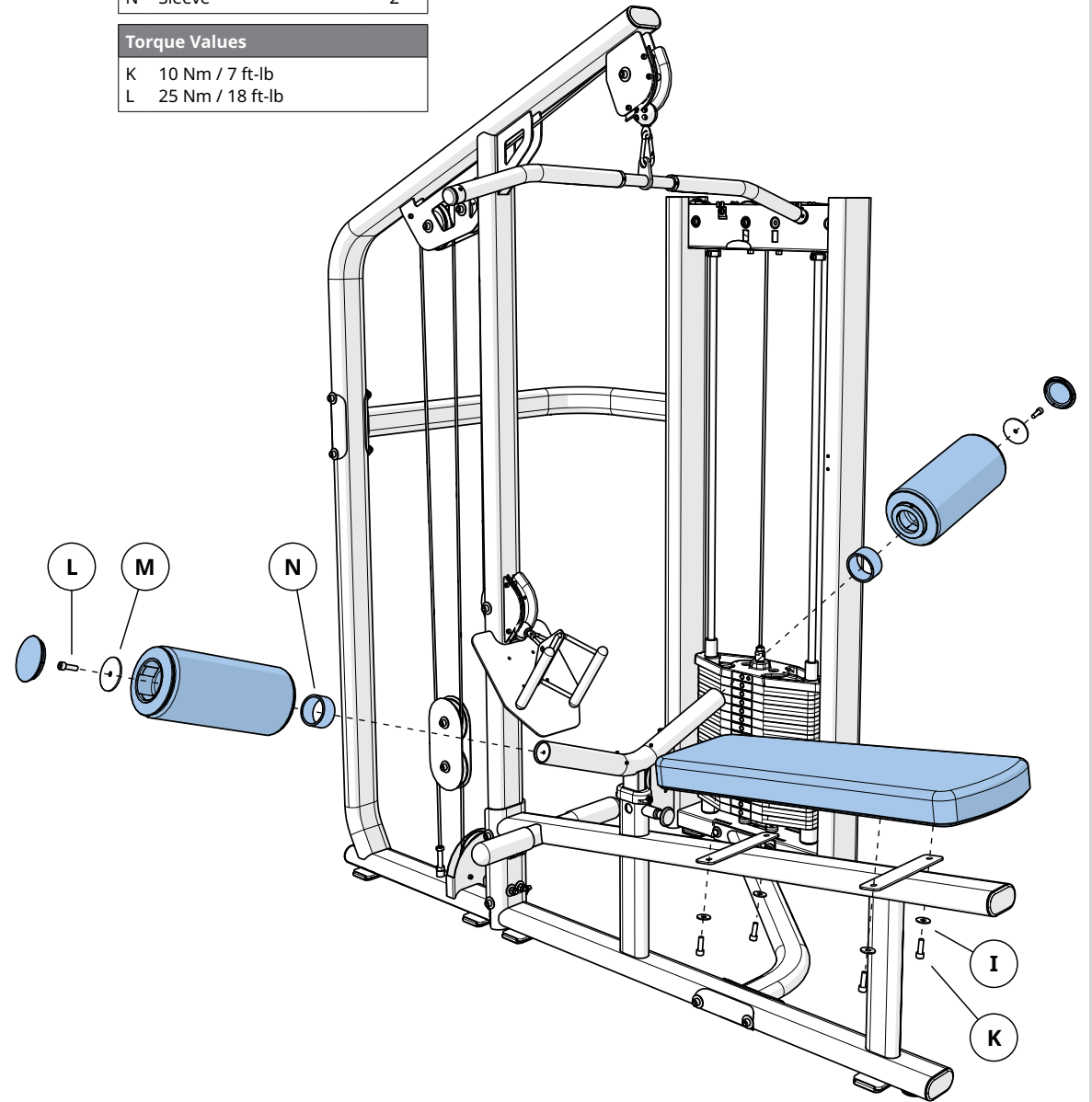



7

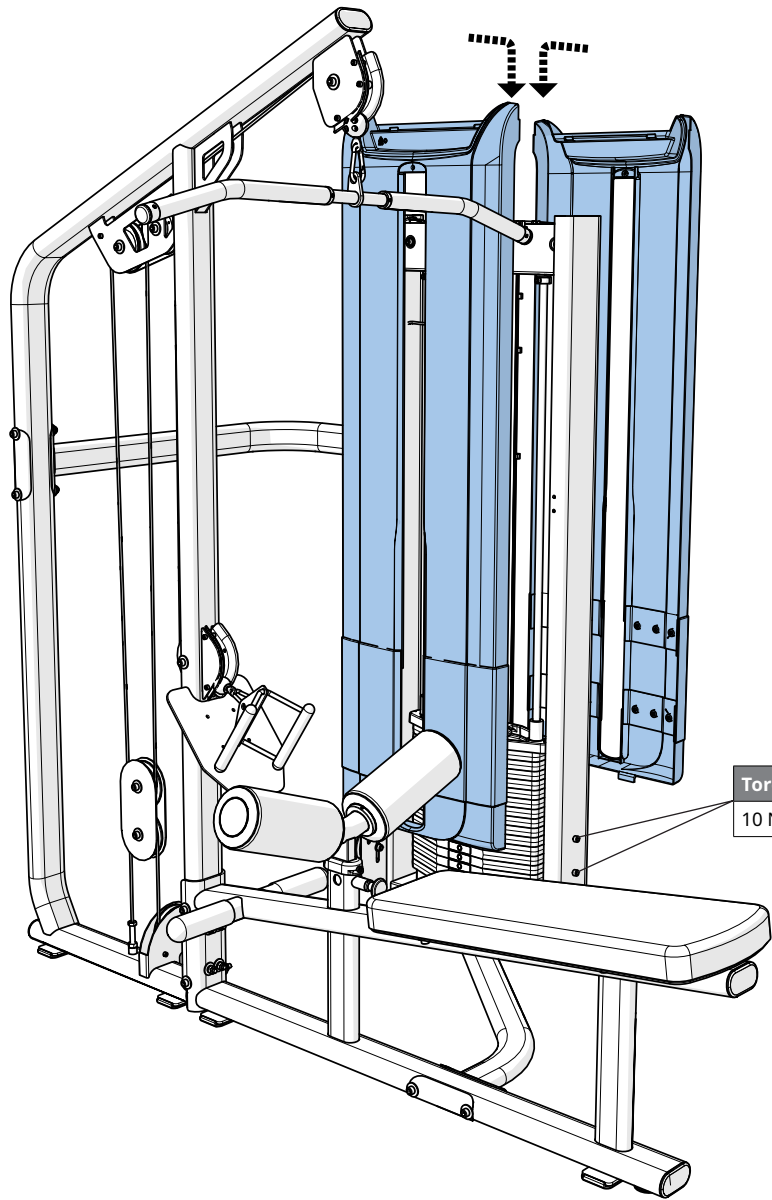

Torque Value
10 Nm / 7 ft-lb

8

Step 9 Hardware	
Description	Qty
O Bolt (M8x25L)	4
P Flat Washer (Φ8.2)	4

Torque Value
15 Nm / 11 ft-lb

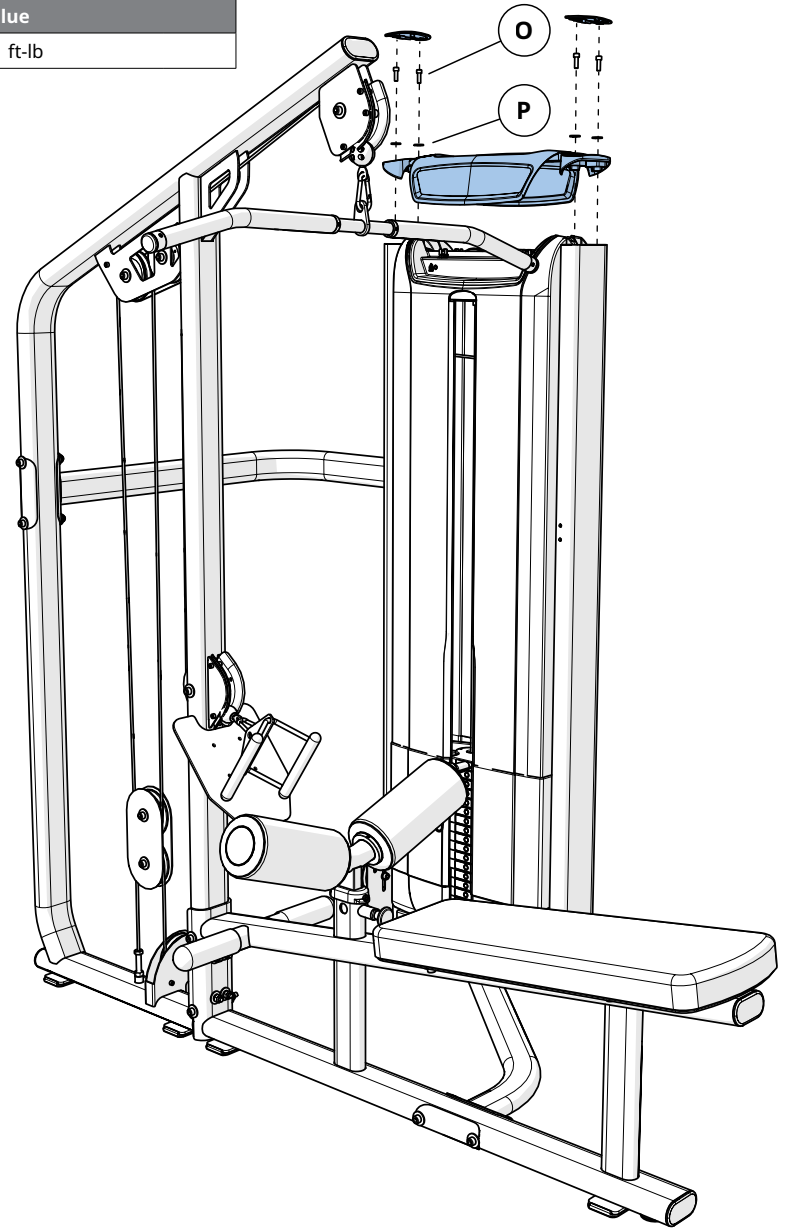

9

Premium Kit (optional)

Step 10 Hardware

Description	Qty
Q Bolt (M8x60L)	4
R Bolt (M8x35L)	2

Torque Value

Q	25 Nm / 18 ft-lb
R	15 Nm / 11 ft-lb

For more info, see weight stack assembly manual.

ASSEMBLY COMPLETE!

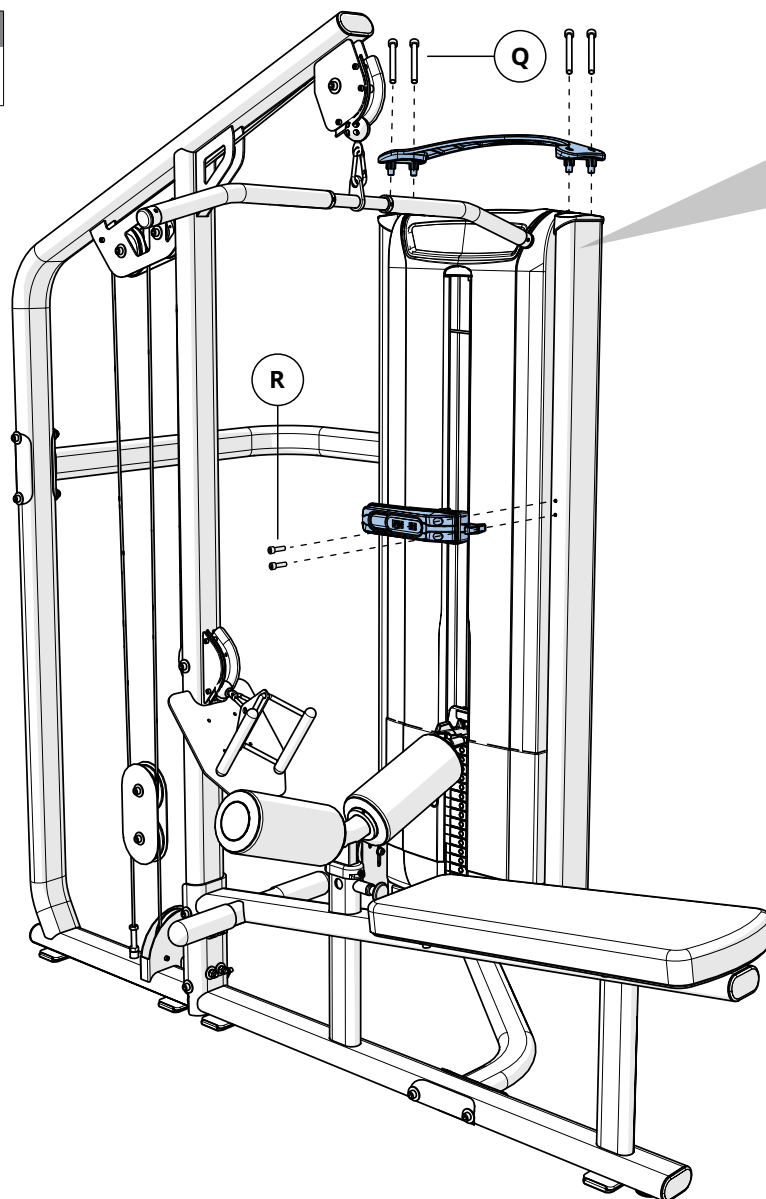

NOTE:
This model uses collars to attach guide rods.

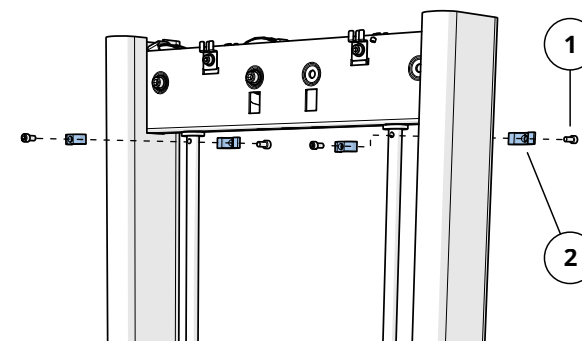

Weight Stack Hardware

Description	Qty
1 Bolt (M8x16L)	4
2 Collar	4



MATRIX